

Non-threaded stud (type US acc. to DIN EN ISO 13918)

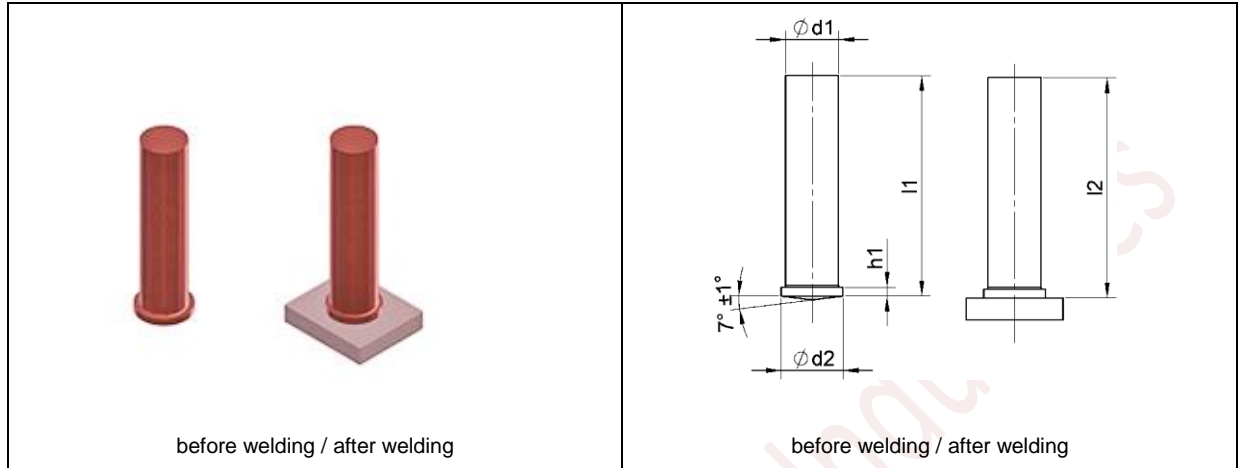

d1 ± 0.1	l1 $+0.6$	d2 ± 0.2	h1	l2
3	6-30	4.5	0.7-1.4	$\approx l1-0.3$
4	6-40	5.5	0.7-1.4	$\approx l1-0.3$
5	6-45	6.5	0.7-1.4	$\approx l1-0.3$
6	8-60	7.5	0.7-1.4	$\approx l1-0.3$
7.1	15-60	9	0.8-1.4	$\approx l1-0.3$
8	15-40	9	0.8-1.4	$\approx l1-0.3$

- Dimensions that are not listed in the measurement tables are delivered on request